

NEU NEW

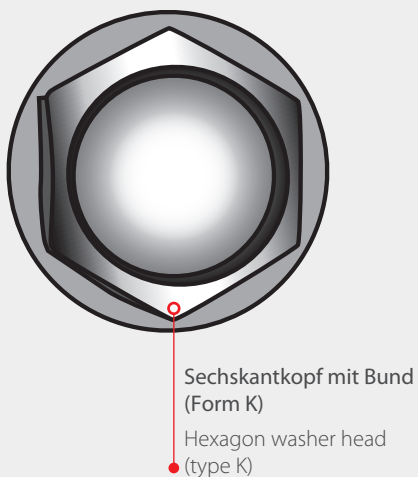
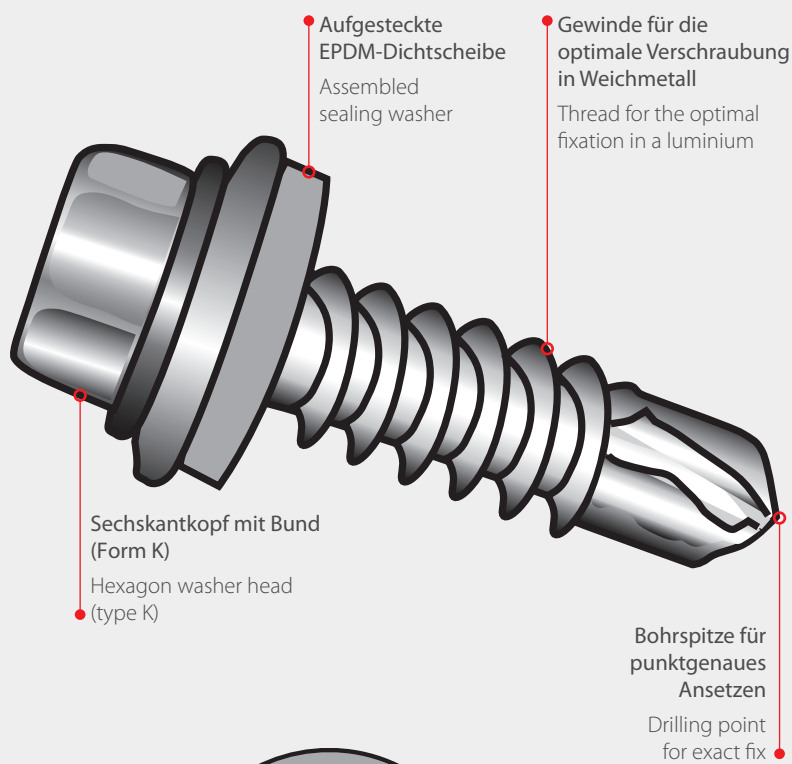

DIN 7504 K0 (~ISO 15480)

A4

NEU – jetzt auch in A4!
Edelstahl-Bohrschrauben mit Sechskant und Bund, Form K
für Weichmetalle (z.B. Aluminium)
mit aufgesteckter EPDM-Dichtscheibe

NEW – now also in A4!
Stainless steel hexagon washer head drilling screws, type K
for soft metals (e.g. aluminium)
with assembled sealing washers



DIN 7504 K0 (~ISO 15480)

A4

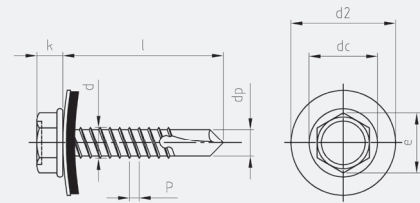

NEU – jetzt auch in A4!

Edelstahl-Bohrschrauben mit Sechskant und Bund, Form K

für Weichmetalle (z.B. Aluminium)

mit aufgesteckter EPDM-Dichtscheibe

Vorteile

Punktgenaues Ansetzen durch die spezielle Bohrspitze, optimale Kraftübertragung (Drehmoment), minimierter Arbeits- und Zeitaufwand (nur ein Arbeitsgang nötig), optimale und saubere Verschraubung, Minimierung von Montage- und Verarbeitungskosten.

Anwendung

Metallbau

NEW – now also in A4!

Stainless steel hexagon washer head drilling screws, type K

for soft metals (e.g. aluminium)

with assembled sealing washers

Advantages

Exact locating due to the special drilling point, ideal power transmission (torque), minimized expenditure of work and time (only one work step necessary), optimal and clean connection, minimization of installation and processing costs.

Application

Metal construction

d	4,2	4,8	5,5	6,3
l/mm				
13	● ■	● ■	● ■	● ■
16	● ■	● ■	● ■	● ■
19	● ■	● ■	● ■	● ■
22	● ■	● ■	● ■	● ■
25	● ■	● ■	● ■	● ■
28			● ■	
30			● ■	
32	● ■	● ■	● ■	● ■
35		● ■	● ■	
38	● ■	● ■	● ■	● ■
40			● ■	
45		● ■	● ■	● ■
50	●	● ■	● ■	● ■
60		● ■	● ■	● ■
70		●	● ■	
75			●	● ■
80			●	
90		●	●	● ■
100		●	●	● ■
110			●	● ■
120			●	
125			●	● ■
130			●	
140			●	
150			●	● ■

	1000 ≥ 38 500 ≥ 50 200	500 ≥ 60 200	500 ≥ 50 200 ≥ 125 100 ≥ 130 200	500 ≥ 50 200 ≥ 100 100
e	7,59	8,71	8,71	10,95
dc	8,8	10,5	11	13,2
k	4,25	4,45	5,45	6,45
p	1,4	1,5	1,7	2
dp	3,6	4,1	4,8	5,8
*	1,75 – 3,0	1,75 – 4,4	1,75 – 5,25	2,0 – 6,0
s	SW7	SW8	SW8	SW10

* Bohrbereich
Drilling capacity

A1 / A2 ● A4 ■

